





Article

Bioaugmentation Treatment of a PAH-Polluted Soil in a Slurry Bioreactor

Rubén Forján ^{1,*}, Iván Lores ², Carlos Sierra ³, Diego Baragaño ¹, José Luis R. Gallego ¹ and Ana Isabel Peláez ²

¹ Indurot and Environmental Technology, Biotechnology and Geochemistry Group, Campus de Mieres, Universidad de Oviedo, 33600 Mieres, Asturias, Spain; diegobcoto@uniovi.es (D.B.); jgallego@uniovi.es (J.L.R.G.)

² Environmental Technology, Biotechnology and Geochemistry Group, Department of Functional Biology, Section of Microbiology–IUBA, University of Oviedo, 33006 Oviedo, Spain; ivan.lores.ovies@gmail.com (I.L.); pelaezana@uniovi.es (A.I.P.)

³ Escuela Superior y Técnica de Ingenieros de Minas y Energía, Universidad de León, 24071 León, Spain; csief@unileon.es

* Correspondence: rforjan@uvigo.es

Received: 29 March 2020; Accepted: 17 April 2020; Published: 20 April 2020



Abstract: A bioslurry reactor was designed and used to treat loamy clay soil polluted with polycyclic aromatic hydrocarbons (PAHs). To this end, biostimulation alone, or combined with bioaugmentation with two bacterial strains (*Rhodococcus erythropolis* and *Pseudomonas stutzeri*) previously isolated from the polluted site, was applied. The PAH concentrations decreased notably after 15 days in all of the treatments. The concentrations of the two- and three-ring compounds fell by >80%, and, remarkably, the four- to six-ring PAHs also showed a marked decrease (>70%). These results thus indicate the capacity of bioslurry treatments to improve, notably, the degradation yields obtained in a previous real-scale remediation carried out using biopiles. In this sense, the remarkable results for recalcitrant PAHs can be attributed to the increase pollutants' bioavailability achieves in the slurry bioreactors. Regarding bioaugmentation, although treatment with *R. erythropolis* led to a somewhat greater reduction of lighter PAHs at 15 days, the most time-effective treatment was achieved using *P. stutzeri*, which led to an 84% depletion of total PAHs in only three days. The effects of microbial degradation of other organic compounds were also monitored by means of combined qualitative and quantitative gas chromatography mass spectrometry (GC–MS) tools, as was the evolution of microbial populations, which was analyzed by culture and molecular fingerprinting experiments. On the basis of our findings, bioslurry technology emerges as a rapid and operative option for the remediation of polluted sites, especially for fine soil fractions with a high load of recalcitrant pollutants.

Keywords: PAH; bioslurry; soil pollution; bioaugmentation; *Pseudomonas*; *Rhodococcus*

1. Introduction

Polycyclic aromatic hydrocarbons (PAHs) are common pollutants produced by industrial activities (chemical and petrochemical industries, energy production, etc.), which involve the use of fossil fuels, as well as from natural events such as forest fires [1]. Affecting more than 200,000 sites in Europe, PAHs are the family of organic contaminants that is most widely encountered [2]. Also, PAHs are abundant pollutants, being present in soil at wood treatment plants, gas works, oil refineries, runoff from asphalt surfaces, and combustion processes. The main properties of PAHs vary in the function of the number of rings, and hence their molecular weight; for instance, the chemical reactivity, aqueous solubility, and volatility of these compounds decrease with increasing the molecular weight,

thus becoming more recalcitrant [3]. The main environmental agencies have identified 16 PAHs as priority pollutants, because they show a greater toxicity than others [4]. Some of these PAHs are toxic, mutagenic, and carcinogenic [5], and they are all highly hydrophobic and thus raise considerable environmental concern [6].

PAHs released into environmental compartments can be removed through processes such as volatilization, photo-oxidation, chemical oxidation, bioaccumulation, and adsorption [7]. Concretely, the remediation of polluted soils can be attained using physical-chemical and/or biological approaches. Indeed, the combination of both technologies can enhance the cleaning of PAH-contaminated soil [8]. In recent decades, the interest in biological methodologies has been growing. In fact, bioremediation can help reduce risks to ecosystems and human health from soil pollution, and effectively restore polluted sites, and they are generally considered environment-friendly treatments. Bioremediation involves the removal of pollutants from a contaminated matrix, or their immobilization or transformation into less toxic products, thereby mitigating their harmful effects [9].

In this context, PAHs can be removed from environmental compartments, such as soils, through microbial transformation and degradation [10]. The microorganisms may be naturally occurring (autochthonous) in the contaminated area, or can be isolated from elsewhere and brought to the site. In the first case, the degradation of hydrocarbons or other organics can be enhanced by providing such microorganisms with nutrients, thereby stimulating their activity [11,12] (biostimulation). In the second case, polluted soils are inoculated with microbial consortia or single isolates [11] (bioaugmentation). Bioremediation is generally performed using one or both of these approaches, depending on the soil conditions and the microbial communities of the study site. In biostimulation, the soil conditions are adjusted with nutrients mainly containing nitrogen and phosphorous; other amendments to control pH or conductivity; and/or a (bio)surfactant in order to increase the bioavailability of the hydrophobic contaminants, thereby increasing bioremediation efficiency [13]. Moreover, soil aeration can increase the microbial count, thereby enhancing the metabolic activities of naturally occurring microbial organisms and accelerating pollutant degradation [14].

The efficiency of bioremediation can be predicted by monitoring the microbial communities [15]. In this regard, bacteria are the prokaryotic microorganisms actively tangled in the degradation of organic pollutants in contaminated sites, and numerous bacterial species can degrade PAHs [12,16]. Contaminated environments, such as soil or sediments, are rich in microorganisms that can metabolize PAHs; thus, a variety of bacteria capable of degrading compounds such as two-ring or three-ring PAHs have been reported [17–19]. Nevertheless, less is known about the capacity of bacteria to metabolize PAHs with five or more rings, such as benzo[a]pyrene and benz[a]anthracene, [20–22]. Nucleic acid-based techniques are feasible approximations [23–25] to carry out microbial monitoring, and molecular techniques have demonstrated their capacity to assess the microbial diversity of several types of environmental samples. Among the latter, fingerprinting methods such denaturing gradient gel electrophoresis (DGGE) allows for the direct visualization of microbial diversity and the rapid comparison of environmental samples [23,26].

The degree and rate of PAH bioremediation depend on many factors, including environmental conditions, PAH properties, and microbial capacity [27]. In this regard, *ex situ* methods, such as bioreactors, permit better control of temperature and amendments to enhance degradation [28]. In particular, slurry bioreactors (SBs) have proven to be suitable for the bioremediation of contaminated soil under controlled environmental conditions [23]. SBs are engineered devices that generally comprise the following four parts: an area for polluted soil handling and conditioning after excavation, the bioreactor battery itself, an area for the handling and disposal of treated soil, and supplementary equipment for the treatment of process by-streams [29]. The main feature of an SB is that the soil inside the reactor is kept in aqueous suspension by mixing, so that the biological activity of the microbial population occurs in saturated conditions and an almost homogeneous suspension [30]. The treatment of soils and sediments in SBs is another option for the bioremediation of soils polluted under controlled conditions [23,31,32]. SBs are also very useful in pilot-scale tests to rapidly evaluate

the feasibility of other bioremediation techniques, such as landfarming and biopiles [33,34]. Actually, under slurry conditions, the rate of pollutant depletion depends mainly on the degradation activity of the microorganisms, and the results obtained largely echo the true biological depuration potential of the polluted soil [35]. Furthermore, in contrast to in situ bioremediation techniques, SB technology implies monitoring several environmental parameters, which can lead to enhanced treatment of the polluted soils. In this regard, SBs can involve the addition of nutrients, inoculum (in the case of using bioaugmentation), a variety of possible electron acceptors, or an increased pollutant availability by means of surfactants addition or biosurfactant production, thereby facilitating the degradation of recalcitrant contaminants or severely weathered mixtures [36,37]. Bioslurry treatments for PAHs at different scales have previously been described [38,39].

Based on our previous experience using a biopile approach, here, we designed a pilot-scale SB to test the capacity of a bioslurry approach to clean highly PAH-polluted soil (see [27] for details). In the referred biopile treatment, the process was successful, but the degradation yields for heavy PAHs were low; therefore, we hypothesize that appropriate conditions in bioslurry reactors could improve biodegradation rates and bioavailability conditions. Therefore, we examined the effectiveness to deplete contaminants and the evolution of the microbial populations involved in the biological process in three scenarios, namely: biostimulation by the autochthonous microbial community of the soil, and bioaugmentation using two degrading strains, namely *Pseudomonas stutzeri* and *Rhodococcus erythropolis*, previously isolated at the study site. The selection of autochthonous bacteria from the polluted site for bioaugmentation purposes is an additional innovative approach that increases the interest of this study; in addition, the comparison with the previous results obtained in real-scale biopiles is also remarkable. Finally, the combination of both qualitative and quantitative Gas chromatography mass spectrometry (GC–MS) analyses revealed a detailed fingerprint of the effects of biodegradation in the complex mixture of contaminants of the study soil.

2. Materials and Methods

2.1. Samples and Soil Characteristics

Soil was collected from a PAH-polluted site in Venta del Gallo (Llanera, Asturias, North Spain; 43°24'52", -5°48'57") at an altitude of 300 m. This site had previously been used by a chemical factory producing naphthalene, resins, phenols, and other compounds from coal tar processing. A wide variety of contaminants were found in the soils of this area (in the 2.5 Ha original parcel and in the surroundings) as a result of spills and unsuitable waste disposal practices over decades [40].

To obtain homogeneous material for slurry bioreactor (SB) experiments, ten samples of contaminated soil (approximately 5 kg each) were taken using a hand-auger (Eijkelkamp), in an area with the average PAH concentrations from within the site, on the basis of data reported by the authors of [27]. All of the samples were then thoroughly mixed to obtain a composite mixture of soil, which was afterwards homogenized and sieved (2-mm mesh size). After a second homogenization, 4-kg representative subsamples of the initial composite sample were taken, labelled, and finally stored at 4 °C, until being used for the bioslurry experiments.

The relevant soil characteristics were determined using standard techniques. pH was determined in a suspension of soil and water (1:2.5) with a glass electrode, and electrical conductivity was measured in the same extract (diluted 1:5). Dichromate oxidation was applied to measure the organic matter content and a Bernard calcimeter for the carbonate content. The Kjeldahl and Olsen methods were used to determine the nitrogen and phosphorus content, respectively.

2.2. Slurry Bioreactor and Experimental Design

The aerobic SB used (Figure 1) was a 40-l stainless-steel recipient designed for pilot-scale experiments. The reactor had a stainless-steel central shaker with speed control, operated in this set of experiments at 150 rpm. A compressor was used to provide oxygenation through an air diffuser located

at the bottom of the reactor. This setup facilitates a regular distribution of air throughout the slurry, thereby keeping solids in suspension. Dissolved oxygen in the slurry was continuously controlled and adjusted initially to 8 mg/L. A heating system (casing) achieved a continuous operational temperature of 28 °C. Oxygen and pH, and temperature probes were continuously monitored by means of several monitoring probes. Also, a pre-treatment tank was used for slurry preparation, which was achieved by blending 4 kg of soil with 20 L of distilled water (1:5 ratio for the solid:liquid relation in the final pulp). After thorough mixing, the slurry was pumped into the SB. The slurry samples were obtained using a sampling valve, and a second pumping system was also available to recover the slurry-load in an outflow tank connected to a chamber filter press. The system was designed to incorporate additional reactors connected in parallel.

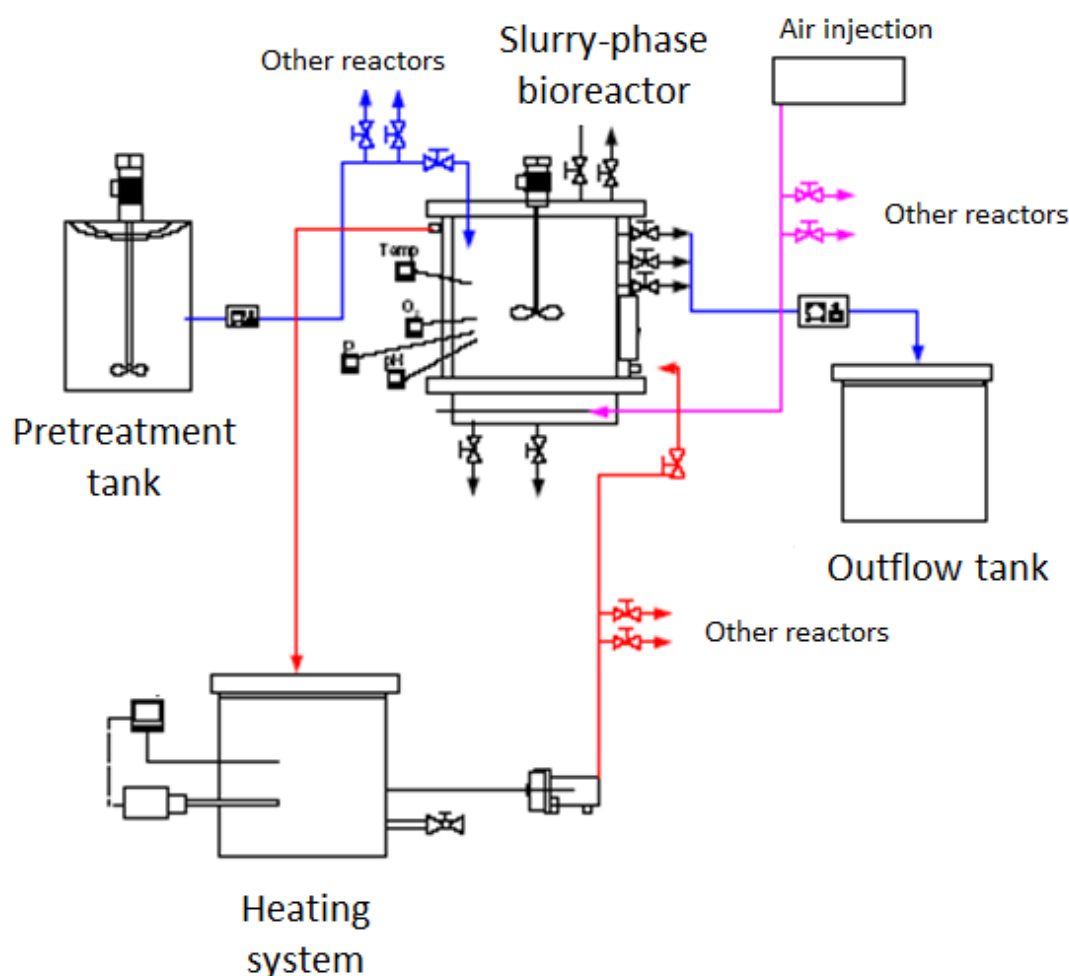

Figure 1. The 40-l slurry bioreactor and auxiliary devices.

Three experiments were performed to study PAH biodegradation in the SB. The first (Treatment A) was based on biostimulation of the autochthonous microbial population by adding nutrients, specifically NH_4NO_3 (two different sources of N) and NaH_2PO_4 (P source and buffer effect), adjusted to a C:N:P ratio of 100:10:1 on the basis of the amount of hydrocarbons present at the beginning of the experiments. A commercial biodegradable surfactant, Bioversal HC (Bioversal International, IEP Europe), was also added at dosages selected on the basis of previous experiences in other studies (including field sites) and on the manufacturer's recommendations [41]. The two other experiments were based on biostimulation of the autochthonous microbial population combined with bioaugmentation with *Rhodococcus erythropolis* (Treatment B) and *Pseudomonas stutzeri* (Treatment C). Both bacteria had previously been isolated from the polluted soil used in this study during a

full-scale biopile treatment at the same site, and showed a high capacity to degrade naphthalene and fluorene [27]. A concentrated inoculum of each bacterium (around 10^8 UFC/mL final bioreactor concentration) was added to the SB at the beginning of each experiment (time 0), and the samples were removed at different times over 15 days to analyze the parameters mentioned below. Samples were transferred to dark bottles, sealed and stored at 4 °C, and analyzed within a week. A summary of the operating conditions and experimental variants measured in the three treatments are shown in Table 1. Furthermore, continuous monitoring of the slurry phase pH, temperature, and dissolved oxygen (DO) was carried out using a Multi 340i apparatus (WTW).

Table 1. Design of bioaugmentation bioslurry experiments.

Reactors	Water (mL)	Soil (g)	Nutrients (g)		Surfactant (mL)	Augmentation
			NH ₄ NO ₃	NaH ₂ PO ₄		
A	20,000	4000	20	4.8	8	-
B	20,000	4000	20	4.8	8	<i>Rhodococcus erythropolis</i>
C	20,000	4000	20	4.8	8	<i>Pseudomonas stutzeri</i>

2.3. Analytical Methods

2.3.1. PAH Analyses

Triplicate slurry samples of 15 mL were obtained from each experiment at 0, 1, 3, 7, and 15 days. They were extracted with hexane:dichloromethane (1:1, *v/v*) in a Soxtherm system (Gerhardt). The extract was concentrated by rotary evaporation. The PAH concentrations were determined by means of a modified Environmental Protection Agency (EPA) method 8272. In brief, the extracts were injected into a 7890A gas chromatograph (GC) System coupled to a 5975C Inert XL Mass Selective Detector (MSD) with a Triple-Axis Detector (Agilent Technologies). A capillary column DB-5ms (5% phenyl 95% dimethylpolysiloxane) 30 m × 0.25 mm i.d. × 0.25 µm film (Agilent Technologies) was used, with helium as the carrier gas at 1 mL/min. The initial oven temperature was 70 °C (held for 2 min) and was ramped up at 20 °C/min to 220 °C, raised to 270 °C at 10 °C/min (held for 1 min), then raised to 290 °C at 10 °C/min (held for 1 min), and finally ramped up at 10 °C/min to 300 °C (held for 7 min). The GC injector was operated in splitless mode for 2 min, and its temperature was maintained at 260 °C. The mass spectrometer was operated in selected ion monitoring mode (SIM), and the quantification of the *m/z* relations was as follows: 128 (Naphthalene); 152, 153, and 154 (Acenaphthylene and Acenaphthene); 165 and 166 (Fluorene); 178 (Phenanthrene and Anthracene); 202 (Fluoranthene and Pyrene); 228 (Benz[a]anthracene and Chrysene); 252 (Benzo[b]fluoranthene, Benzo[k]fluoranthene, and Benzo[a]pyrene); and 276 and 278 (Dibenz[a,h]anthracene, Benzo[ghi]perylene, and Indene[1,2,3-cd]pyrene). The MS worked in electron ionization mode (EI) at 70 eV, and it was calibrated daily by auto-tuning with perfluorotributylamine (PFTBA). PAH calibration mixtures (AccuStandard) were used.

2.3.2. Qualitative GC-MS

The supplementary characterization of other organic pollutants and monitoring of the biodegradation were also performed with a qualitative GC-MS approach. In this case, the purified extracts were injected into a gas chromatograph (GC) system HP 6890 Series equipped with a capillary column (AT5 Alltech, 25 m length and 0.25 mm internal diameter) operating in full-scan mode (*m/z* between 50 and 450). The column oven temperature was raised from 60 °C to 300 °C at 6 °C/min, and the injector temperature was set at 275 °C. This equipment was coupled to a mass detector (MSD) HP 5973 Series, which allowed for peak area determinations and for the identification of mass spectra by means of the Wiley 275 database.

2.4. Microbiological Methods

2.4.1. Plate Counting, Isolation, and Identification

Another set of slurry samples of 15 mL was obtained to monitor microbial evolution. For bacterial counts, the suspensions were allowed to settle, and 0.1 mL of clear supernatant was used to carry out ten-fold serial dilutions for inoculating plates with a GAE (Glucose, Asparagine, Yeast Extract) medium (10 g/L glucose; 0.5 g/L yeast extract; 1 g/L L-asparagine; 0.5 g/L $\text{MgSO}_4 \cdot 7\text{H}_2\text{O}$; 0.01 g/L FeSO_4 ; 20 g/L agar). The plates were incubated for 48–72 h at 30 °C, and viable colonies were then determined and expressed as Colony-Forming Units per ml (CFU/ml). Also, distinct morphologies of colonies were selected on the basis of their abundance, and were cultured in the same medium until their purity was checked.

Purified bacteria were identified by 16S rDNA gene sequencing after the amplification of the gene by polymerase Chain Reaction (PCR) using a Minicycler™ (MJ Research). An almost full-length bacterial 16S rDNA sequence (1500 bp) was amplified using primers 27F and 1492R [42], and purified using the GFX™ PCR DNA and Gel Band Purification Kit (Amersham Biosciences) for automated DNA sequencing. The PCR products amplified from cultured isolates were screened by Restriction Fragment Length Polymorphism (RFLP) analysis using *Hae*III and *Alu*I endonucleases. The profiles were analyzed on a 3% agarose gel in Tris/Borate/EDTA (TBE), followed by SYBR Gold (Invitrogen) staining and visualization under UV light. Then, 16S rDNA sequences showing the same profile were grouped and considered a unique ribotype. Only one representative of each ribotype was sequenced. The 16S rDNA sequences were obtained using an ABI Prism™ 3100 Genetic Analyzer (Perking Elmer) and were compared with the GenBank sequences; this was done using the USA National Center for Biotechnology Information NCBI's Basic Local Alignment Search Tool (BLAST) [43]. Taxonomic denominations were obtained following the RDP II [44].

2.4.2. Denaturing Gradient Gel Electrophoresis (DGGE)

The evolution of the microbial population during the bioslurry treatments was monitored by DGGE on the samples taken at different times. The total bacterial DNA was extracted from 0.25 mL of slurry by means of a DNA extraction kit (POWERSOIL, Mobio Laboratories Inc., USA). Whole-community DNA from each sample was subjected to PCR amplification using primers GC-341F and 907R [45], targeting the V3–V5 region of the 16S rDNA gene. The GC-341F primer included a GC clamp at the 5'-end. PCR reactions were performed in the Minicycler referred to above, and DGGE was carried out on the PCR products (550 pb). Approximately 400 ng of PCR product was loaded onto a 6% (*w/v*) polyacrylamide gel with a thickness of 0.75 mm (to obtain better resolution), with denaturing gradients ranging from 45% to 65% (100% denaturant contains 7 M urea and 40% formamide). DGGE was performed in a 1× TAE buffer (40 mM Tris, 20 mM sodium acetate, 1 mM EDTA, pH 7.4) at 70 V and 60 °C for 16 h. The DGGE gels were visualized under UV light and digitalized with the UV Gel Logic 200 Imaging System (KODAK). The DGGE bands were managed using Quantity-one version 4.1 image analysis software (Bio-Rad Laboratories) and were corrected manually.

3. Results and Discussion

3.1. Soil Characterization

Analyses of the study soil (Table 2) showed a loamy clay soil, with a slightly alkaline pH (8.2), a conductivity of 0.13 dS m^{-1} and low levels of nitrogen, phosphorus, and organic matter (Table 2), typical of infertile soils. The main matrix of the soil was sandy (siliceous), although a high proportion of clay was also present.

Table 2. Original soil characteristics; the values shown are an average of three measurements on distinct samples.

Texture	Sand (2 mm–63 µm)	43%
	Silt (63–2 µm)	19%
	Clay (<2 µm)	39%
Chemical parameters	pH	8.2
	Conductivity	0.13 dS/m
	Organic matter	0.20 % <i>w/w</i>
	Nitrogen	0.03 % <i>w/w</i>
	C/N ratio	3.9
	Phosphorus	<2.6 mg/kg
	Carbonate content	0.8 % <i>w/w</i>
Microbiology	Total heterotrophs	2.3×10^8 CFU/g soil
PAH content	mg/kg	332.2

CFU: Colony-Forming Units.

3.2. Chemical Analysis

The three bioslurry (Treatments A, B, and C) treatments were monitored regularly for slurry phase pH, temperature, and dissolved oxygen. The temperature was constant at around 28 °C throughout all of the treatments, as initially set up. However, the DO levels (Figure 2) started close to 8.0 mg/L, but were then rapidly reduced to a quasi-constant value of 5 mg/L in the three experiments, thereby indicating an active consumption in the context of an aerobic process. Similarly (Figure 2), the pH showed an increase at early time points from around 7.0, up to levels close to 8.0 in all of the treatments.

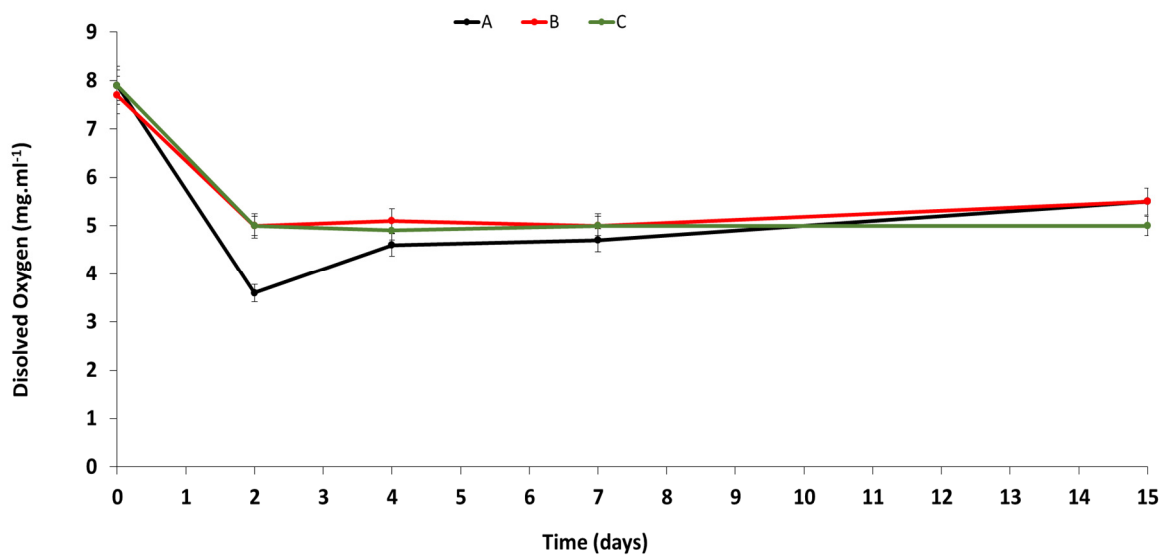

Figure 2. Cont.

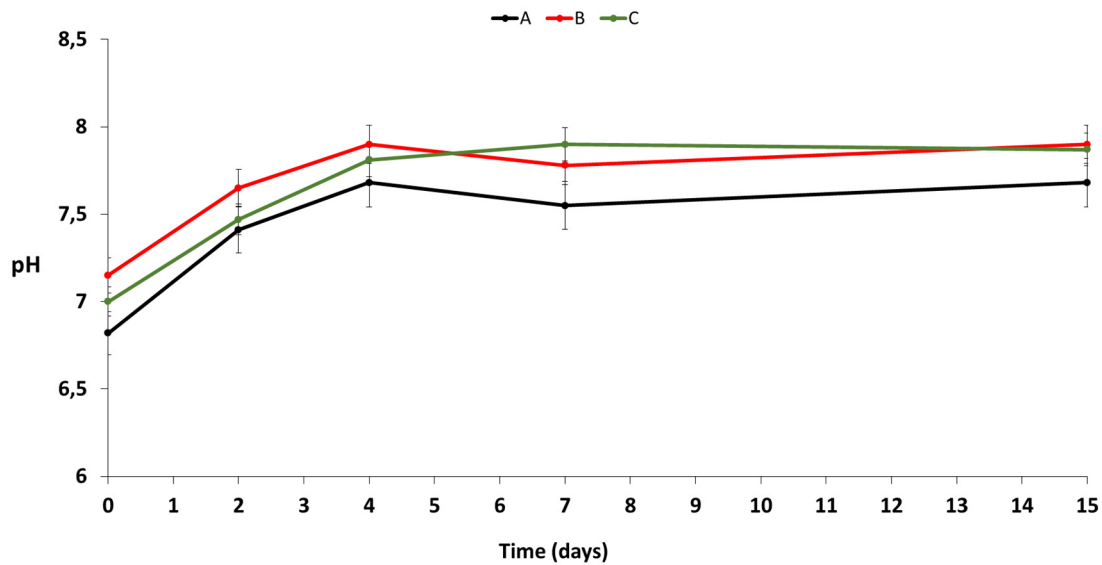

Figure 2. Evolution of the dissolved oxygen (top) and pH (bottom) of the three bioslurry experiments.

Regarding PAH depletion, after 15 days of treatment, the bioaugmentation treatments (with *Rhodococcus* and *Pseudomonas*) registered slightly lower PAH concentrations than the biostimulation treatment alone (named Autochthonous in Figure 3). However, the evolution of the three experiments was not same. The depletion of PAHs was noticeably faster when *P. stutzeri* was added, whereas the effect of *R. erythropolis* appeared to be slower. However, the extent of degradation finally achieved in both experiments was similar and analogous to that obtained in the biostimulation experiment alone.

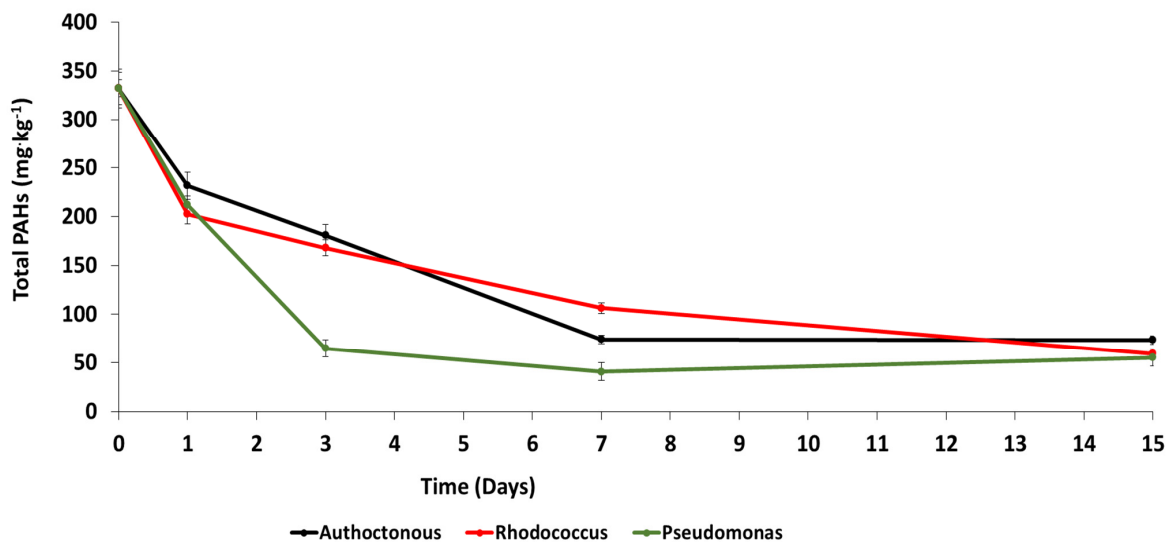

Figure 3. Evolution of the total polycyclic aromatic hydrocarbon (PAH) concentration during the bioslurry reactor experiments.

A more detailed overview of the degradation results is shown in Table 3. Of note, there was an apparent favored degradation of the lighter PAHs (two- and three-ring compounds) with respect to the heavy PAHs (four- to six-ring), regardless of the treatment. This finding is consistent with the differences in the bioavailability of the contaminants [46]. However, the differences between the depletion achieved for lighter or heavier PAHs were not notable in our case (between only 10% and 20%, depending on the experiment). This result could be attributable to the controlled and favorable conditions of the reactor experiments to increase bioavailability, including the addition of

the surfactant and even possible biosurfactant production by some of the degrading microorganisms present (see below). Our findings indicate that the microorganisms showed a sufficient degradation capacity to deplete quasi-recalcitrant compounds such as heavy PAHs (more than 70% of degradation); i.e., the controlled optimal conditions of the SB facilitated a greater yield than that achieved in the pilot-scale on-site biopile treatments (as reported in the literature [27], after 60 days less than 40% of heavy PAHs were degraded). In fact, bioavailability constraints are essential factors for hydrocarbon biodegradation [41,47], especially significant in aged soils such as the one studied here, where lipophilic contaminants had enough time to diffuse into the soil micropores, thereby becoming inaccessible to microorganisms [48]. Subsequently, a residual contaminants fraction, usually associated with the finer grain-sizes (note the remarkable presence of clays in our case), typically remains in the soil [49]. Our bioslurry approach, together with bioaugmentation processes using well-known PAH-degraders capable of producing biosurfactants such as *P. stutzeri* [50,51] and *R. erythropolis* [52,53], overcame these difficulties.

Table 3. Evolution of PAH content (mg/kg) in the six pilot-scale parcels. The relative standard deviations (RSD) for PAHs were in a range, from a minimum of 1% for Benzo[a]anthracene to a maximum of 9% for Naphthalene.

	Initial	1 day			3 days			7 days			15 days			% Reduction after 15 days		
		A	B	C	A	B	C	A	B	C	A	B	C	A	B	C
two-ring PAHs	145.7	104.1	72.2	80.2	76.1	67.9	23.0	26.7	37.5	12.6	25.1	15.6	20.7	82.8	89.3	85.8
three-ring PAHs	108.3	70.0	71.5	70.0	53.9	49.0	17.1	25.5	37.3	12.0	26.8	22.0	15.7	75.3	79.7	85.5
four- to six-ring PAHs	78.0	57.6	58.8	61.9	51.0	51.2	24.8	22.2	31.8	16.3	21.9	21.8	19.0	72.0	72.0	75.6
Total PAHs	332.2	231.7	202.5	212.2	180.9	168.1	64.9	74.4	106.5	40.9	73.7	59.4	55.5	77.8	82.1	83.3

On the whole, the three experiments showed similar results after 15 days, although Treatment A (only autochthonous microorganisms) showed a slightly inferior performance. Nevertheless, Treatment C (addition of *Pseudomonas* strain) achieved a greater degradation of all fractions of the PAHs at three days, thereby suggesting a much better adaptation and/or synergies with the autochthonous microbial populations. Given this result, we propose that the *Pseudomonas* strain would be useful to accelerate the degradation process in a real-scale treatment in larger bioreactors.

Regarding the qualitative evolution of the contaminants, there was a remarkable reduction in the abundance and variety of the initial pool of contaminants after 15 days of treatment (Figures 4 and 5; for more details about the variety of contaminants present on this site, see [40]). This reduction affected mainly lighter PAHs and specially alkyl-PAHs (see peaks 6, 8, 17, and 21 in Figure 4). However, there was also an evident decrease in the unresolved complex mixture (UCM), heavy PAHs, and heterocyclic compounds. Conversely, a recalcitrant compound different to PAHs (Bis(2-ethylhexyl)phthalate (DEHP), peak 24 in Figure 4 and labelled in Figure 5) was not affected.

In addition, although present at much lower contents than PAHs, n-alkanes were notably degraded (Figure 4). This finding indicates the wide metabolic abilities of the soil microorganisms, which attacked both aromatic and aliphatic compounds. Of note, although the lighter n-alkanes were relatively much more degraded than the heavier ones, the latter were also clearly biodegraded, as occurred with the aromatic fraction (Figure 4). The relative depletion of n-C₁₇ and n-C₁₈, when compared with isoprenoids such as phytane and pristane, indicates a preferential degradation of linear alkanes, as observed in other studies [41,54].

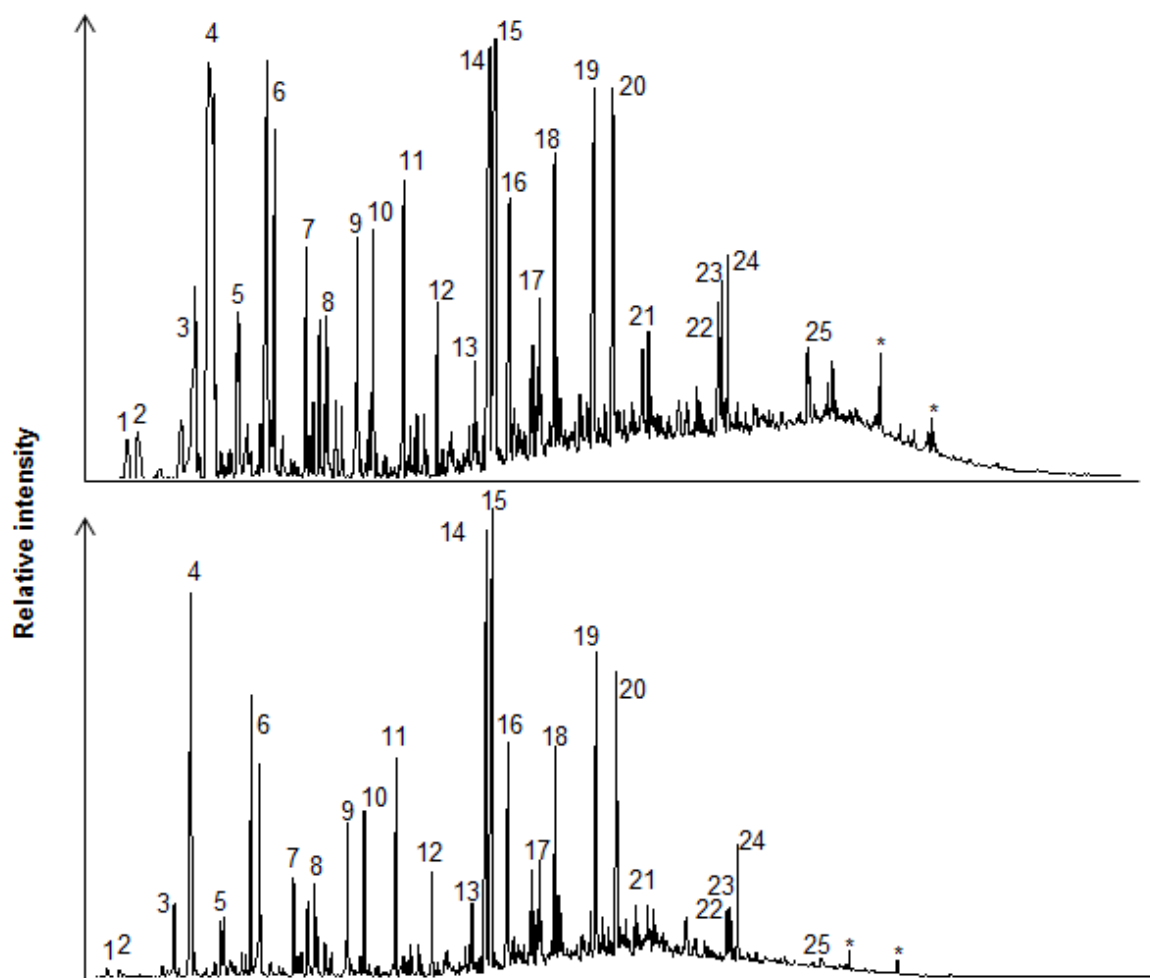

Figure 4. Total ion chromatogram (TIC) of the contaminants mixture of the study soil at the beginning (top) and after 15 days of treatment (bottom; control treatment). (1) Indene; (2) Methyl-phenol; (3) Cresols; (4) Naphthalene; (5) Quinoline; (6) C1-Alkyl-naphthalenes; (7) Biphenyl; (8) C2-Alkyl-naphthalenes; (9) Acenaphthene; (10) Dibenzofuran; (11) Fluorene; (12) Tetramethyl-biphenyl; (13) Dibenzothiophene; (14) Phenanthrene; (15) Anthracene; (16) Carbazole; (17) C1-Alkylanthracenes and phenanthrenes; (18) Dimethoxy-dimethylbiphenyl; (19) Fluoroanthene; (20) Pyrene; B[a]P; (21) C1-Alkylpyrenes; (22) Benzo[a]Anthracene; (23) Chrysene; (24) Bis(2-ethylhexyl)phthalate (DEHP); (25) Benzo[a]pyrene and other five- and six-ring PAHs; * procedure contaminant.

3.3. Evolution of Bacterial Quantity and Diversity during the Bioslurry Treatments

The plate count numbers of the culturable bacteria showed low variation during biostimulation (Treatment A; data not shown). In the *Rhodococcus* biostimulation–bioaugmentation experiment (Treatment B), there was a decrease in the early stages from 10^8 to 10^7 CFU/g at seven days. However, the values increased to 3.0×10^7 after 15 days, suggesting possible competition between the augmentation strain used (*Rhodococcus*) and the native bacteria. This finding correlates with the lower rates of PAH degradation observed in the early times compared with the other reactors (Figure 3). In contrast, the addition of *Pseudomonas* (Treatment C) was accompanied by a slight increase of more than 10^8 CFU/g at three days and the simultaneous disappearance of PAHs (Figure 3). From this time point, the number of bacteria decreased, reaching around 3.0×10^7 CFU/g at the end of the treatment.

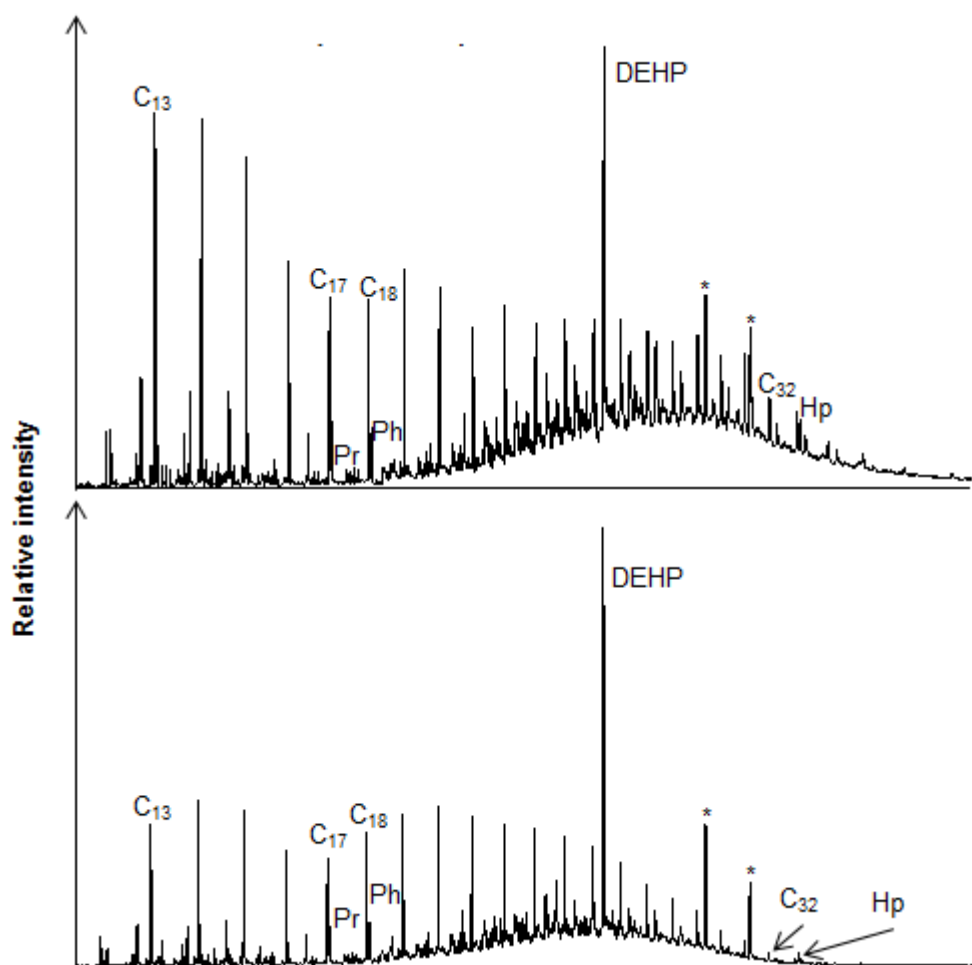

Figure 5. Single ion mode (SIM) chromatogram of ion (m/z): 57 representative of alkanes of the study soil at the beginning (top) and after 15 days of treatment (bottom; control treatment). Ci— n -alkanes of the “i” carbons chain. Pr—Pristane; Ph—Phytane; Hp—Hopanes; DEHP—Bis(2-ethylhexyl)phthalate * procedure contaminant.

The analysis of the soil culturable bacteria of the bioreactor experiments also provided useful additional information on their capacity to degrade PAHs. Twenty predominant aerobic bacterial colonies with distinct morphologies (colour, texture, size, etc.) were isolated from the bioreactor at various time points. The RFLP profiles obtained after the digestion of the 16S rDNA showed the presence of 10 distinct ribotypes (Table 4). Phylogenetic affiliation was assigned by sequencing the 16S rRNA genes and carrying out a subsequent comparison with the sequences deposited in the GenBank DNA.

Microbacterium (class Actinobacteria) has been described to degrade PAHs, as has *Diaphorobacter* (belonging to the class Betaproteobacteria, family Comamonadaceae) and *Pseudoxanthomonas* (phylum Proteobacteria, family Xanthomonadaceae), which have been reported as pyrene degraders. Various species of the genus *Olivibacter* (phylum Bacteroidetes, class Sphingobacteriaceae) degrade hydrocarbons and can be found in contaminated soils and waste [55]. *Rhizobium* belongs to the Rhizobiaceae family, of the class Alphaproteobacteria, which can degrade phenanthrene, alone or in consortium with *Pseudomonas* and other bacteria [56,57].

Table 4. Identification and phylogenetic assignation (RFLP, Restriction Fragment Length Polymorphism) of culturable bacteria isolated from the three bioslurry experiments. Gray fills indicate the presence of the bacteria in the corresponding experiment.

Phylogenetic Affiliation	Similarity %	Identified Bacteria	Experiments		
			A	B	C
Actinobacteria	98	<i>Microbacterium</i>			
Sphingobacteria	100	<i>Olivibacter soli</i>			
Gammaproteobacteria	98	<i>Pseudomonas chlororaphis</i>			
Betaproteobacteria	98	<i>Diaphorobacter</i>			
Gammaproteobacteria	99	<i>Pseudoxanthomonas</i> sp.			
Gammaproteobacteria	99	<i>Pseudomonas</i> sp.			
Gammaproteobacteria	99	<i>Pseudomonas stutzeri</i>			
Actinobacteria	98	<i>Rhodococcus erythropolis</i>			
Alphaproteobacteria	99	<i>Rhizobium</i> sp.			
Gammaproteobacteria	99	<i>Pseudomonas alcaligenes</i>			

As usually occurs in hydrocarbon-enriched environments [27], phylum Proteobacteria of the class Gammaproteobacteria and specifically the *Pseudomonas* genera were predominant in the culturable bacteria isolated. Various PAH degrader species of *Pseudomonas* have been isolated from batch and bioslurry experiments, and strains of *Pseudomonas*, *Rhodococcus*, and *Burkholderia* species have been successfully used for pyrene degradation in microcosm experiments with contaminated soil [22]. The efficiency of *P. stutzeri* for bioaugmentation in PAH bioremediation is also supported by a previous study conducted at the bioreactor scale [58]. *Pseudomonas* and *Rhodococcus* have also been described as integrating bacterial consortia for PAH degradation [59].

Notably, most of the isolated bacteria appeared in at least two of the three experimental conditions, thereby suggesting that the associated environmental changes, if any, do not significantly affect bacterial populations. Interestingly, *R. erythropolis*, which was added to Treatment B, was found only in this reactor, while *P. stutzeri*, added to Treatment C, was present in all three experiments. Therefore, it appears that the persistence of *R. erythropolis* under the experimental conditions used was lower than that of *P. stutzeri*. This remark is consistent with the distinct degrading capacities of the two bacteria. In this regard, while *R. erythropolis* showed a greater capacity to reduce lighter PAHs at 15 days (Table 3), *P. stutzeri* showed much greater efficiency at shorter times and a greater reduction of all PAHs at 15 days (Table 3 and Figure 3). In turn, the DGGE fingerprint analysis (Figure 6) of the microbial community during the treatments confirmed the persistence of many bands (that is, the maintenance of bacterial populations, as previously discussed). However, variations in the intensity of the bands were also appreciated. The analysis of the isolated *R. erythropolis* and *P. stutzeri* strains used for bioaugmentation supports the persistence of the latter in the three experimental conditions tested, as also shown by the culture experiments.

Detailed analysis of the microbial activities using omic techniques, similar to those already used in the full-scale biopile treatment performed at the same site [25], will provide additional useful information for the rational selection of the most suitable bacteria for bioaugmentation purposes.

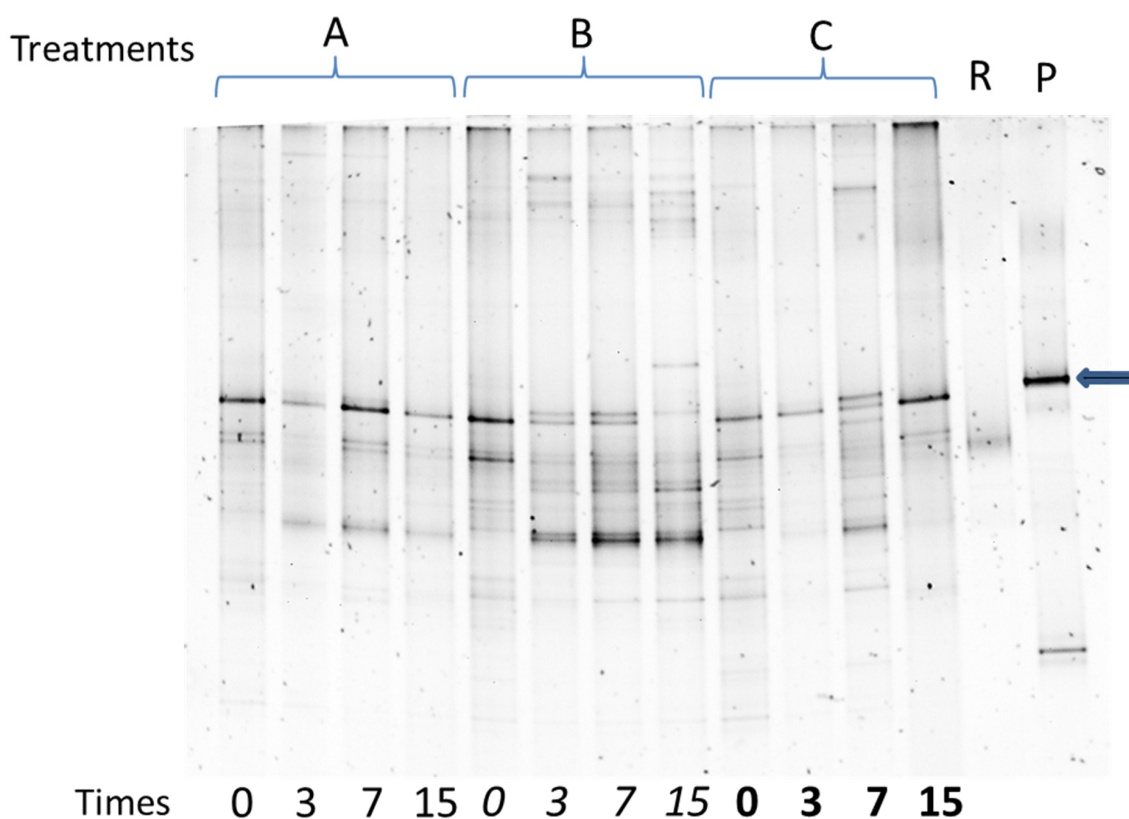

Figure 6. Denaturing gradient gel electrophoresis (DGGE) analysis of the bioslurry reactors. (A) biostimulation treatment at times 0, 3, 7, and 15 days; (B) *Rhodococcus* biostimulation-bioaugmentation experiment; (C) the same from *Pseudomonas* biostimulation-bioaugmentation experiment; R and P bands correspond to *R. erythropolis* and *P. stutzeri* alone, respectively (arrow).

4. Conclusions

This work has revealed the usefulness of bioaugmentation for degrading PAHs in slurry bioreactor experiments, as well as the complexity of the microbial relationships during the treatments. A notable reduction of PAH (above 80%) content was achieved in very short periods (less than two weeks), irrespective of the use of the autochthonous microbial populations (biostimulation) or the addition of previously isolated specialized microbes (bioaugmentation). The control of the environmental conditions in the bioreactors facilitated the bioavailability of the pollutants (linked to the production of bacterial biosurfactants), and subsequently allowed notable yields of PAH depletion. In this sense, in a previous real-scale study, around 40% of the PAHs were degraded in biopiles in two months (mostly two- and three-ring PAHs were depleted), whereas in this work, the yields were duplicated in a shorter period (15 days), and the degradation notably affected heavy PAHs and other organics, as shown by GC-MS qualitative and quantitative analyses. Therefore, although bioslurry approaches are less cost-effective than landfarming or biopiles, they should be considered when designing real-scale treatments of heavy PAHs or other recalcitrant organics. Given that the scale-up needed to treat high volumes of soil might not be affordable, the treatment of only heavily polluted fine fractions (such as those tested in this study) may be a good option, in combination with soil washing or other technologies. In turn, bioaugmentation with autochthonous bacteria was revealed in this work as a promising tool. In particular, *P. stutzeri* could be helpful to accelerate the process in a real-scale treatment involving several larger bioreactors. A detailed analysis of the microbial interactions in these processes will provide complementary information to facilitate the rational selection of the most suitable bacteria for bioaugmentation purposes.

Author Contributions: Conceptualization, C.S., J.L.R.G and A.I.P.; experimentation and methodology, I.L. and D.B.; resources, J.L.R.G and A.I.P.; writing—original draft preparation, R.F., J.L.R.G. and A.I.P.; writing—review and editing, R.F., J.L.R.G. and A.I.P. All authors have read and agreed to the published version of the manuscript.

Funding: This work was supported by the project CTM2016-75894-P (funded by AEI/FEDER, UE). We would like also to thank the Environmental Testing Unit of the Scientific and Technical Resources of the University of Oviedo for their support. Diego Baragaño obtained a grant from the “Formación del Profesorado Universitario” program, financed by the “Ministerio de Educación, Cultura y Deporte de España”.

Conflicts of Interest: The authors declare no conflict of interest.

References

1. Mueller, J.; Chapman, P.; Pritchard, P. Creosote contaminated sites: Their potential for biodegradation. *Environ. Sci. Technol.* **1989**, *23*, 1197–1201. [[CrossRef](#)]
2. Biaché, C.; Ouali, S.; Cébron, A.; Lorgeoux, C.; Colombano, S.; Fauré, P. Bioremediation of PAH-contaminated soils: Consequences on formation and degradation of polar-polycyclic aromatic compounds and microbial community abundance. *J. Hazard. Mater.* **2017**, *329*, 1–10. [[CrossRef](#)]
3. Cheung, P.Y.; Kinkle, B.K. *Mycobacterium* diversity and pyrene mineralization in petroleum-contaminated soils. *Appl. Environ. Microbiol.* **2001**, *67*, 2222–2229. [[CrossRef](#)]
4. ATSDR. Toxicology profile for polyaromatic hydrocarbons. In *ATSDR's Toxicological Profiles on CD-ROM*; CRC Press: Boca Raton, FL, USA, 2005.
5. Sato, H.; Aoki, Y. Mutagenesis by environmental pollutants and bio-monitoring of environmental mutagens. *Curr. Drug Metab.* **2002**, *3*, 311–319. [[CrossRef](#)]
6. Rodrigo, J.; Santos, R.; Bento, F.; Perariba, M.; Selbach, P.; Sa, S.; Camargo, F. Anthracene biodegradation by *Pseudomonas* sp. Isolated from a petrochemical sludge landfarming site. *Int. Biodeter. Biodegr.* **2005**, *56*, 143–150.
7. Beesley, L.; Moreno-Jiménez, E.; Gomez-Eyles, J.L. Effects of biochar and greenwaste compost amendments on mobility, bioavailability and toxicity of inorganic and organic contaminants in a multi-element polluted soil. *Environ. Pollut.* **2010**, *158*, 2282–2287. [[CrossRef](#)]
8. Kuppusamy, S.; Thavamani, P.; Venkateswarlu, K.; Lee, Y.B.; Naidu, R.; Megharaj, M. Remediation approaches for polycyclic aromatic hydrocarbons (PAHs) contaminated soils: Technological constraints, emerging trends and future directions. *Chemosphere* **2017**, *168*, 944–968. [[CrossRef](#)]
9. Viesser, J.A.; Sugai-Guerios, M.H.; Malucelli, L.C.; Pincerati, M.R.; Karp, S.G.; Maranhão, L.T. Petroleum-Tolerant Rhizospheric Bacteria: Isolation, Characterization and Bioremediation Potential. *Sci. Rep.* **2020**, *10*, 2060. [[CrossRef](#)]
10. Alegbeleye, O.O.; Opeolu, B.O.; Jackson, V.A. Polycyclic Aromatic Hydrocarbons: A Critical Review of Environmental Occurrence and Bioremediation. *Environ. Manag.* **2017**, *60*, 758–783. [[CrossRef](#)]
11. Bento, F.M.; Camargo, F.A.O.; Okeke, B.C.; Frankenberger, W.T. Comparative bioremediation of soils contaminated with diesel oil by natural attenuation, biostimulation and bioaugmentation. *Bioresour. Technol.* **2005**, *96*, 1049–1055. [[CrossRef](#)]
12. Megharaj, M.; Ramakrishnan, B.; Venkateswarlu, K.; Sethunathan, N.; Naidu, R. Bioremediation approaches for organic pollutants: A critical perspective. *Environ. Int.* **2011**, *37*, 1362–1375. [[CrossRef](#)]
13. Whang, L.M.; Liu, P.W.G.; Ma, C.C.; Cheng, S.S. Application of Biosurfactants, Rhamnolipid, and Surfactin, for Enhanced Biodegradation of Diesel-Contaminated Water and Soil. *J. Hazard.* **2008**, *151*, 155–163. [[CrossRef](#)]
14. Teng, Y.; Luo, Y.; Ping, L.; Zou, D.; Li, Z.; Christie, P. Effects of soil amendment with different carbon sources and other factors on the bioremediation of an aged PAH-contaminated soil. *Biodegradation* **2010**, *21*, 167–178. [[CrossRef](#)]
15. Lin, T.C.; Pan, P.T.; Cheng, S.S. Ex situ bioremediation of oil-contaminated soil. *J. Hazard. Mater.* **2010**, *176*, 27–34. [[CrossRef](#)]
16. Robles-González, I.V.; Fava, F.; Poggi-Varaldo, H.M. A review on slurry bioreactors for bioremediation of soils and sediments. *Microb. Cell Fact.* **2008**, *7*, 5. [[CrossRef](#)]
17. Haritash, A.K.; Kaushik, C.P. Biodegradation aspects of Polycyclic Aromatic Hydrocarbons (PAHs): A review. *J. Hazard. Mater.* **2009**, *169*, 1–15. [[CrossRef](#)]

18. Kim, J.D.; Shim, S.H.; Lee, C.G. Degradation of phenanthrene by bacterial strains isolated from soil in oil refinery fields in Korea. *J. Microbiol. Biotechnol.* **2005**, *15*, 337–345.
19. Tirado-Torres, D.; Acevedo-Sandoval, O.; Rodríguez-Pastrana, B.R.; Gayosso-Canales, M. Phylogeny and polycyclic aromatic hydrocarbons degradation potential of bacteria isolated from crude oil-contaminated site. *J. Environ. Sci. Health A Tox Hazard. Subst. Environ. Eng.* **2017**, *52*, 897–904. [[CrossRef](#)]
20. Hou, N.; Zhang, N.; Jia, T.; Sun, Y.; Dai, Y.; Wang, Q.; Li, D.; Luo, Z.; Li, C. Biodegradation of phenanthrene by biodemulsifier-producing strain *Achromobacter* sp. LH-1 and the study on its metabolisms and fermentation kinetics. *Ecotoxicol. Environ. Saf.* **2018**, *163*, 205–214. [[CrossRef](#)]
21. Peng, R.H.; Xiong, A.S.; Xue, Y.; Fu, X.Y.; Gao, F.; Zhao, W.; Tian, Y.S.; Yao, Q.H. Microbial biodegradation of polyaromatic hydrocarbons. *FEMS Microbiol. Rev.* **2008**, *32*, 927–955. [[CrossRef](#)]
22. Moscoso, F.; Teijiz, I.; Deive, F.J.; Sanromán, M.A. Efficient PAHs biodegradation by a bacterial consortium at flask and bioreactor scale. *Bioresour. Technol.* **2012**, *119*, 270–276. [[CrossRef](#)] [[PubMed](#)]
23. Vaidya, S.; Jain, K.; Madamwar, D. Metabolism of pyrene through phthalic acid pathway by enriched bacterial consortium composed of *Pseudomonas*, *Burkholderia*, and *Rhodococcus* (PBR). *Biotech* **2017**, *7*, 29. [[CrossRef](#)] [[PubMed](#)]
24. Andreoni, V.; Gianfreda, L. Bioremediation and monitoring of aromatic-polluted habitats. *Appl. Microbiol. Biotechnol.* **2007**, *76*, 287–308. [[CrossRef](#)] [[PubMed](#)]
25. Guazzaroni, M.E.; Herbst, F.; Tamames, J.; Lores, I.; Peláez, A.I.; López-Cortés, N.; Vieites, J.M.; Gallego, J.L.R.; Pieper, D.; Rosselló-Móra, R.; et al. Metaproteogenomic insights beyond bacterial response to naphthalene exposure and bio-stimulation. *ISME J.* **2013**, *7*, 122–136. [[CrossRef](#)]
26. Ruffini, M.; Giorgetti, L.; Becarelli, S.; Siracusa, G.; Lorenzi, R.; Di Gregorio, S. Polycyclic aromatic hydrocarbon-contaminated soils: Bioaugmentation of autochthonous bacteria and toxicological assessment of the bioremediation process by means of *Vicia faba* L. *Environ. Sci. Pollut. Res. Int.* **2016**, *23*, 7930–7941. [[CrossRef](#)]
27. Pelaez, A.I.; Lores, I.; Sotres, A.; Mendez-Garcia, C.; Fernandez-Velarde, C.; Santos, J.A.; Gallego, J.L.R.; Sanchez, J. Design and field-scale implementation of an “on site” bioremediation treatment in PAH-polluted soil. *Environ. Pollut.* **2013**, *181*, 190–199. [[CrossRef](#)]
28. Alexander, M. *Biodegradation and Bioremediation*, 2nd ed.; Academic Press: San Diego, CA, USA, 1999; pp. 325–327.
29. Montante, G.; Pinelli, D.; Magelli, F. Scale-up criteria for the solids distribution in slurry reactors stirred with multiple impellers. *Chem. Eng. Sci.* **2003**, *58*, 5363–5372. [[CrossRef](#)]
30. Mueller, J.G.; Lantz, S.E.; Blattman, B.O.; Chapman, P.J. Bench-scale evaluation of alternative biological treatment processes for the remediation of pentachlorophenol and creosote contaminated materials: Slurry-phase bioremediation. *Environ. Sci. Technol.* **1991**, *25*, 1045–1055. [[CrossRef](#)]
31. Christodoulatos, C.; Koutsospyros, A. Bioslurry reactors. In *Biological Treatment of Hazardous Wastes*; Lewandowsky, G.A., De Filippi, L.J., Eds.; John Wiley & Sons, Inc.: New York, NY, USA, 1998; pp. 69–103.
32. Mohan, V.S.; Shailaja, S.; Krishna, M.R.; Reddy, K.B.; Sarma, P.N. Bioslurry phase degradation of di-ethyl phthalate (DEP) contaminated soil in periodic discontinuous mode operation: Influence of bioaugmentation and substrate partition. *Process Biochem.* **2006**, *41*, 644–652. [[CrossRef](#)]
33. He, Y.; Chi, J. Pilot-scale demonstration of phytoremediation of PAH-contaminated sediments by *Hydrilla verticillata* and *Vallisneria spiralis*. *Environ. Technol.* **2019**, *40*, 605–613. [[CrossRef](#)]
34. Li, F.; Guo, S.; Wu, B.; Wang, S. Pilot-scale electro-bioremediation of heavily PAH-contaminated soil from an abandoned coking plant site. *Chemosphere* **2020**, *244*, 125467. [[CrossRef](#)]
35. Evans, B.S.; Dudley, C.A.; Klasson, K.T. Sequential anaerobic-aerobic biodegradation of PCBs in soil slurry microcosms. *Appl. Biochem. Biotechnol.* **1996**, *57*, 885–894. [[CrossRef](#)]
36. Machin-Ramirez, C.; Okoh, A.I.; Morales, D.; Mayolo-Deloisa, K.; Quintero, R.; Trejo-Hernández, M.R. Slurry-phase biodegradation of weathered oily sludge waste. *Chemosphere* **2008**, *70*, 737–744. [[CrossRef](#)]
37. Nasser, S.; Kalantary, R.R.; Nourieh, N.; Naddafi, K.; Mahvi, A.H.; Baradaran, N. Influence of bioaugmentation in biodegradation of PAHs-contaminated soil in bio-slurry phase reactor. *J. Environ. Health Sci. Eng.* **2010**, *7*, 199–208.
38. Chiavola, A.; Baciocchi, R.; Gavasci, R. Biological treatment of PAH-contaminated sediments in a Sequencing Batch Reactor. *J. Hazard. Mater.* **2010**, *184*, 97–104. [[CrossRef](#)]

39. Yu, C.C.; Chang, T.C.; Liao, C.S.; Chang, Y.T. A comparison of the microbial community and functional genes present in free-living and soil particle-attached bacteria from an aerobic bioslurry reactor treating high-molecular-weight PAHs. *Sustainability* **2019**, *11*, 1088. [[CrossRef](#)]
40. Lara-Gonzalo, A.; Kruge, M.A.; Lores, I.; Gutiérrez, B.; Gallego, J.R. Pyrolysis GC-MS for the rapid environmental forensic screening of contaminated brownfield soil. *Org. Geochem.* **2015**, *87*, 9–20. [[CrossRef](#)]
41. Gallego, J.L.R.; Sierra, C.; Permanyer, A.; Peláez, A.I.; Menéndez-Vega, D.; Sánchez, J. Full-scale remediation of a jet fuel-contaminated soil: Assessment of biodegradation, volatilization, and bioavailability. *Water Air Soil Pollut.* **2011**, *217*, 197–211. [[CrossRef](#)]
42. Ikenaga, M.; Muraoka, Y.; Toyota, K.; Kimura, M. Community structure of the microbiota associated with nodal roots of rice plants along with the growth stages: Estimation by PCR-RFLP analysis. *Biol. Fertil. Soils* **2002**, *36*, 397–404. [[CrossRef](#)]
43. Altschul, S.F.; Madden, T.L.; Schäffer, A.A.; Zhang, J.; Zhang, Z.; Miller, W.; Lipman, D.J. Gapped BLAST and PSI-BLAST: A new generation of protein database search programs. *Nucleic Acids Res.* **1997**, *25*, 3389–3402. [[CrossRef](#)]
44. Cole, J.R.; Wang, Q.; Cardenas, E.; Fish, J.; Chai, B.; Farris, R.J.; Kulam-Syed-Mohideen, A.S.; McGarrell, D.M.; Marsh, T.; Garrity, G.M.; et al. The Ribosomal Database Project: Improved alignments and new tools for rRNA analysis. *Nucleic Acids Res.* **2009**, *37*, D141–D145. [[CrossRef](#)]
45. Muyzer, G.; Teske, A.; Wirsén, C.O.; Jannasch, H.W. Phylogenetic relationships of Thiomicrospira species and their identification in deep-sea hydrothermal vent samples by denaturing gradient gel electrophoresis of 16S rDNA fragments. *Appl. Environ. Microbiol.* **1995**, *164*, 165–172.
46. Gallego, J.R.; Sierra, C.; Villa, R.; Peláez, A.I.; Sánchez, J. Weathering processes only partially limit the potential for bioremediation of hydrocarbon-contaminated soils. *Org. Geochem.* **2010**, *41*, 896–900. [[CrossRef](#)]
47. Huesemann, M.H. Incomplete hydrocarbon biodegradation in contaminated soils: Limitations in bioavailability or inherent recalcitrance? *Bioremediat. J.* **1997**, *1*, 27–39. [[CrossRef](#)]
48. Ortega, J.J.; Ball, W.P.; Schulin, R.; Semple, K.T.; Wick, L.Y. Bioavailability of pollutants and soil remediation. *J. Environ. Qual.* **2007**, *36*, 1383–1384. [[CrossRef](#)]
49. Nocentini, M.; Pinelli, D.; Fava, F. Bioremediation of a soil contaminated by hydrocarbon mixtures: The residual concentration problem. *Chemosphere* **2000**, *41*, 1115–1123. [[CrossRef](#)]
50. Rabodonirina, S.; Rasolomampianina, R.; Krier, F.; Drider, D.; Merhaby, D.; Net, S.; Ouddane, B. Degradation of fluorene and phenanthrene in PAHs-contaminated soil using pseudomonas and bacillus strains isolated from oil spill sites. *J. Environ. Manag.* **2019**, *232*, 1–7. [[CrossRef](#)]
51. Wang, B.; Xu, X.; Yao, X.; Tang, H.; Ji, F. Degradation of phenanthrene and fluoranthene in a slurry bioreactor using free and ca-alginate-immobilized sphingomonas pseudosanguinis and pseudomonas stutzeri bacteria. *J. Environ. Manag.* **2019**, *249*, 109388. [[CrossRef](#)]
52. Morales, P.; Cáceres, M.; Scott, F.; Díaz-Robles, L.; Aroca, G.; Vergara-Fernández, A. Biodegradation of benzo[α]pyrene, toluene, and formaldehyde from the gas phase by a consortium of rhodococcus erythropolis and fusarium solani. *Appl. Microbiol. Biotechnol.* **2017**, *101*, 6765–6777. [[CrossRef](#)]
53. Hu, X.; Qiao, Y.; Chen, L.; Du, J.; Fu, Y.; Wu, S.; Huang, L. Enhancement of solubilization and biodegradation of petroleum by biosurfactant from rhodococcus erythropolis HX-2. *Geomicrobiol. J.* **2020**, *37*, 159–169. [[CrossRef](#)]
54. Gallego, J.R.; Fernández, J.R.; Díez-Sanz, F.; Ordoñez, S.; Sastre, H.; González-Rojas, E.; Peláez, A.I.; Sánchez, J. Bioremediation for shoreline cleanup: In situ vs. on-site treatments. *Environ. Eng. Sci.* **2007**, *24*, 493–504. [[CrossRef](#)]
55. Ntougias, S.; Lapidus, A.; Han, J.; Mavromatis, K.; Pati, A.; Chen, A.; Klenk, H.; Woyke, T.; Fasseas, C.; Kyrpides, N.C.; et al. High quality draft genome sequence of Olivibacter sitiensis type strain (AW-6T), a diphenol degrader with genes involved in the catechol pathway. *Stand. Genom. Sci.* **2014**, *9*, 783. [[CrossRef](#)]
56. Wang, J.; Xu, H.; Guo, S. Isolation and characteristics of a microbial consortium for effectively degrading phenanthrene. *Pet. Sci.* **2007**, *4*, 68–75. [[CrossRef](#)]
57. Huang, X.; Shi, J.; Cui, C.; Yin, H.; Zhang, R.; Ma, X.; Zhang, X. Biodegradation of phenanthrene by Rhizobium petrolearium SL-1. *J. Appl. Microbiol.* **2016**, *121*, 1616–1626. [[CrossRef](#)]

58. Álvarez, M.S.; Rodríguez, A.; Sanromán, M.A.; Deive, F.J. Simultaneous biotreatment of Polycyclic Aromatic Hydrocarbons and dyes in a one-step bioreaction by an acclimated *Pseudomonas* strain. *Bioresour. Technol.* **2015**, *198*, 181–188. [[CrossRef](#)]
59. Mrozika, A.; Piotrowska-Seget, Z. Bioaugmentation as a strategy for cleaning up of soils contaminated with aromatic compounds. *Microbiol. Res.* **2009**, *165*, 363–375. [[CrossRef](#)]



© 2020 by the authors. Licensee MDPI, Basel, Switzerland. This article is an open access article distributed under the terms and conditions of the Creative Commons Attribution (CC BY) license (<http://creativecommons.org/licenses/by/4.0/>).